

# The SA-6 mk3/12 Area Alarm

for

## Piped Medical Gases

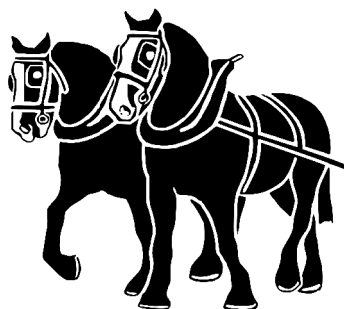

### Installation & Operating Instructions

The SA-6 mk3 area alarm is designed to monitor piped gas pressure, pressure switches, in theatres, wards etc. after final Area Valve Service AVSUs) or in industrial or laboratory applications. The SA-6 mk3 will act as a slave to another SA-6 mk3 within 250 metres, using a three screened cable (4 cores if signals are to be returned to the master unit).



## About this manual

When you see this symbol, the associated text in bold type refers to something which may cause danger or damage.

## Mounting

Surface mounting. Mount the enclosure with the "TOP" sticker uppermost. Flush mounting. Fit the back box in the wall so that the front edge is from 2 to 15 mm lower than the finished wall surface. When the wall is finished, attach the bezel to the back box, using the 4M3 x 25mm countersunk screws provided, with the hinge mounting to the left. Connect the earth lead on the bezel to the adjacent M4 stud in the box.

Take the battery from the packing & stand it, on end, in the right hand end of the box. Connect the red & black leads to the red & black terminals.

### **OBSERVE POLARITY**

## Connecting.

Bring the cables into the box in areas as shown on the drawings.

## Supply.

**WARNING. This equipment is not suitable for connection to an IT power system. A readily accessible means of disconnecting the supply must be provided. The maximum prospective fault current must not exceed 1500 amps.**

Remove the "Warning" cover to reveal the mains terminals. Connect Live, Neutral and Earth to L, N & PE. Replace the "Warning" Cover, making a cut-out in the side to allow the cable to pass. (The supply required is 240 V a.c., 50 or 60 Hz, fused at 3 amp. unless otherwise marked.) Signals. Connect signalling devices i. e. pressure switches) with screened cable, SWA or single core cable in steel conduit or trunking.

**The cable, conduit or trunking must not be shared with any other system. Cables**

## Connection as a slave unit.

The inter-panel wiring between master and slave units is as follows.

Master		Slave
SO (Strobe Out)	to	SI (Strobe In)
DO (Data Out)	to	gas input terminals H & L
CM (Common)	to	CM (Common)

The following connection is only required if a gas is to be sent from slave to master:  
gas input terminals H & L to DO (Data Out)

In addition, units to be used as masters must have SO (Strobe Out) connected to their SM (Strobe Monitor) terminal (all panels are dispatched with this connection made). If the unit is to be used as a slave, this link must be removed and the SM (Strobe Monitor) terminal must be connected to the SI (Strobe In) terminal.

**must have a minimum of 20mm clearance from any other cables.**

For medical applications which require cable monitoring, a termination board (supplied with the panel) must be mounted in or by the plant or pressure switches for each service. (The termination boards can be supplied mounted in boxes if required). The plant or pressure switches are connected to the "PLANT" terminals on this board, and the alarm terminals are connected to the "ALARM" terminals. Terminal "L" is for low pressure or vacuum, "H" is for high pressure and "C" is common. Unscreened cable may be used for runs up to 10 metres provided that there is no possibility of interference i.e. mains cables. Unused conditions should be set to normal by connecting a 56k resistor (colour coded green, blue, orange, silver or gold) between "C" and the "L" or "H" terminal on the alarm power supply board as required. Failure to do this will create a "System Fault" (open circuit) resulting in the condition staying at fault and the System Fault lamp flashing. For medical applications which do not require cable monitoring (when the alarm panel is mounted in the same enclosure as the pressure switches) and for non medical applications, the H, L & C terminals are connected directly to the pressure switches. Unused inputs are linked to C or left open when the alarm is set to operate with normally open contacts.

## Output.

Change-over contacts are provided, which are in the following state only when all conditions are at normal

"CM"=common.

"C"=closed.

"O"=open.

These contacts are rated at 0.5 amp, 1 IOVac, 1 amp, 24Vdc resistive.

# Battery

Select the required mode of battery operation with the Battery Mode Selector. With the red jumper across the centre & right hand pins (marked >M) full battery reserve is in operation. With the jumper across the centre & left hand pins, HTM02 mode is in operation (maximum battery life)

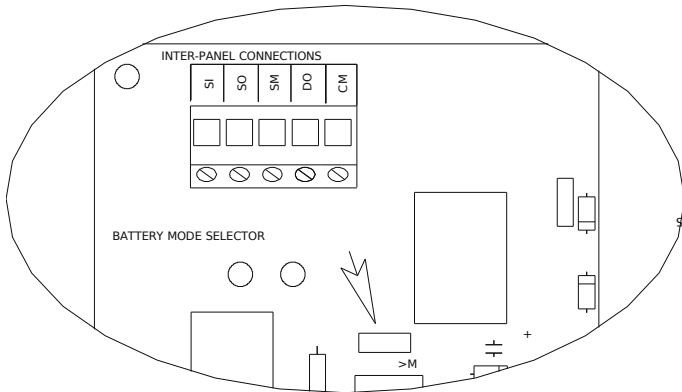

## Operation.

When all conditions and the power supply are at normal, the Power On and Normal lamps only are on. If any signal contact opens, the appropriate Normal lamp goes out, the appropriate red Fault lamp will flash and the audible will sound. If the signal cable is short or open circuited on an SA-6 mk3, the alarm condition will operate as above but the System Fault lamp will also flash. In the event of power failure, if the battery mode is set to HTM02 mode, only the System Fault lamp and the audible will operate otherwise operation is as follows: When the power fails, the Power On lamp will go out, the System Fault lamp will flash and the audible will sound. All other lamps will continue to function normally. If the audible is not muted for approximately 25 minutes, all lamps except the System Fault will go out. As soon as the audible is muted or the power returns, the lamps will operate as normal. A fault on the Strobe line on a unit used as a slave (for example, failure of the master or its power supply or damage to the cabling) will cause the System Fault lamp to illuminate continuously, all High & Low lamps to flash and the audible to sound. Failure of the Data In line on a unit receiving

signals from another unit (Master or Slave) will create a System Fault on all gases received by this unit. If any gas or system fault is present, the output relay will be de-energised, only reenergising when all gases and power are at normal.

## Muting.

The audible is muted by depressing the Mute/Test button then releasing. The audible will then stop. The audible will re-trigger after a nominal 15 minutes. It can then be re-muted.

## Lockout.

If an alarm condition is to be in a fault condition for a prolonged period, the audible on this condition can be permanently muted as follows.

Open the panel.

Create the alarm condition.

Press the white Lockout button, mounted on the PCB, until the audible stops.

Close the panel.

Note. Any other conditions present at this time, if muted or not, will also be locked out. The lockout can be verified by pressing the Mute/Test button. Lamps for conditions which are locked out will be steady. The lockout condition is cancelled as soon as the condition returns to normal. A System Fault cannot be locked out.

## Testing.

Periodically operate the Mute/Test button. All red alarm lamps should flash, all green lamps and the System Fault lamps should show continuously and the audible should sound. Red alarm lamps for conditions which are locked out will be steady. Release the button. After a short delay, all conditions should return to normal operation and the audible should stop. Periodically switch off the mains supply. Lamps should operate as described earlier. After a short delay, the audible should sound and the System Fault lamp should flash. When the mains supply is switched back on, all conditions should return to normal operation.



# JUMPER SETTINGS FOR SA-6 area alarm

## MODE OF OPERATION

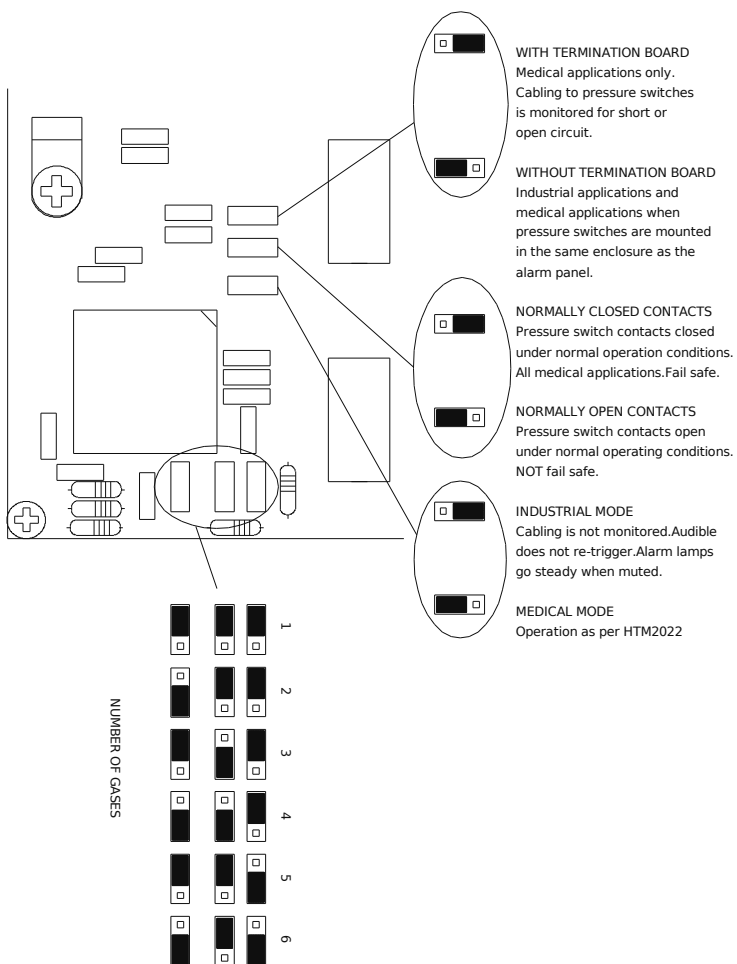

## TYPICAL AREA ALARM INSTALLATION

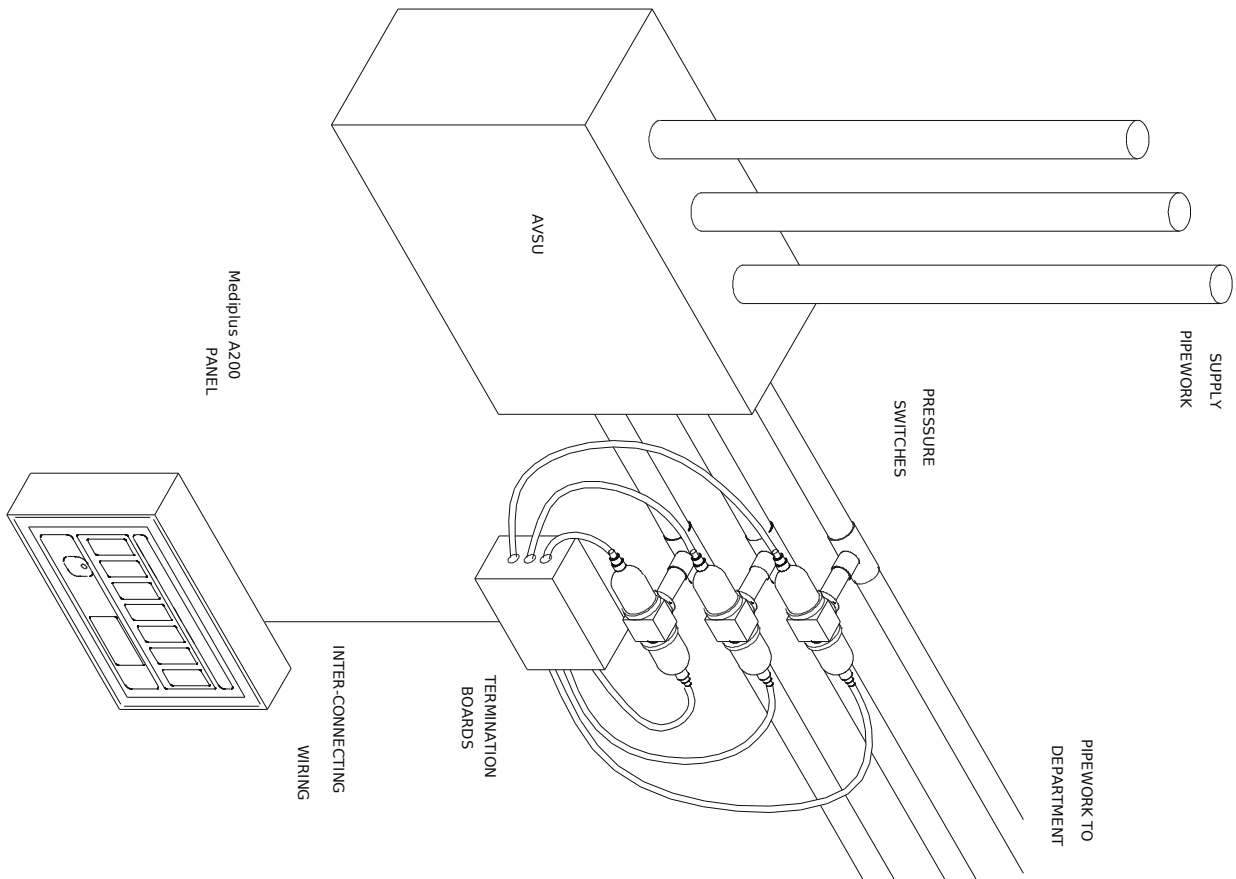

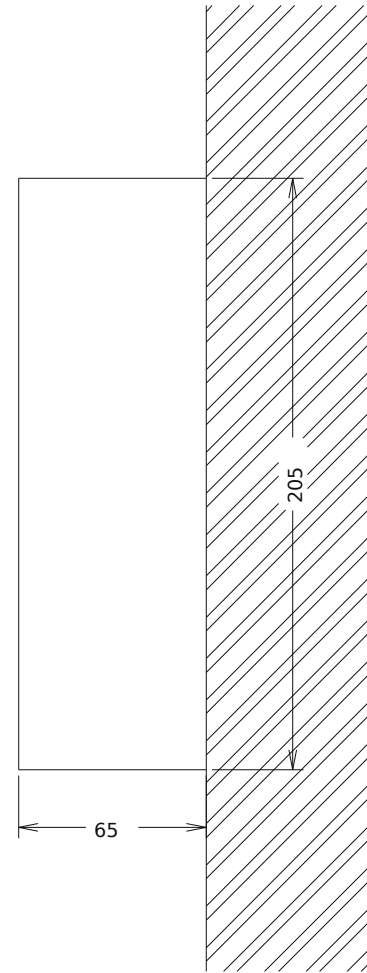
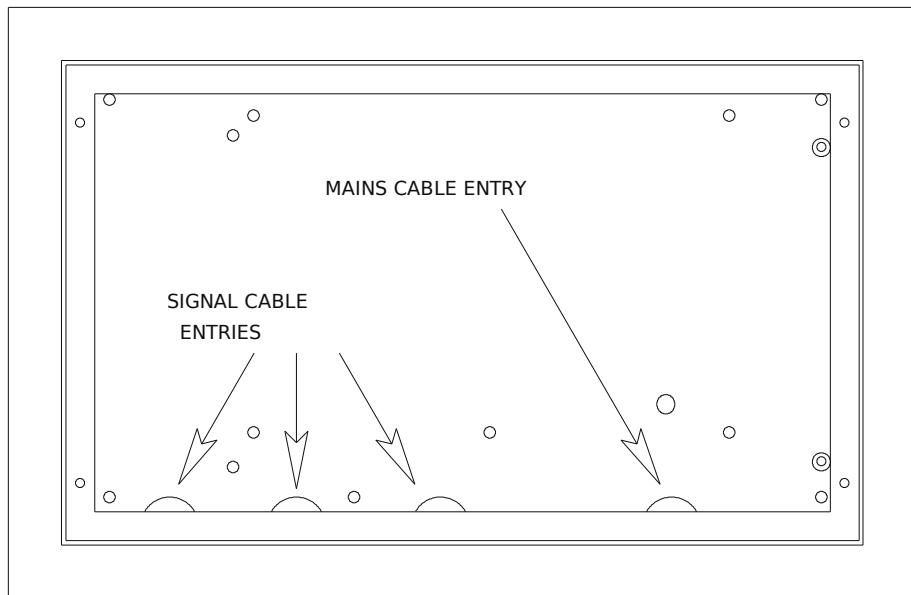
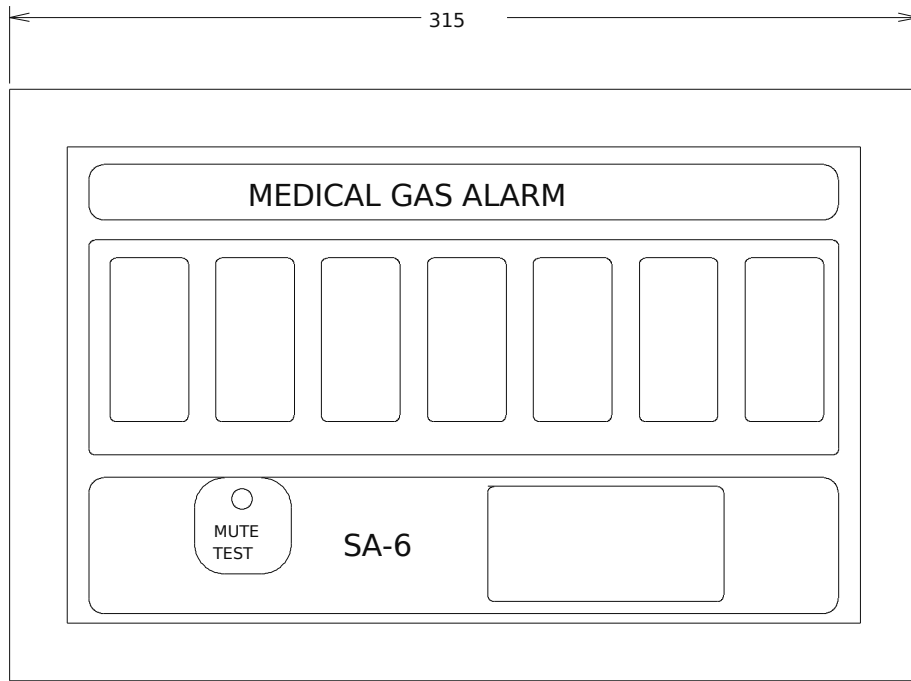

SURFACE MOUNTING

M10944 21-10-96

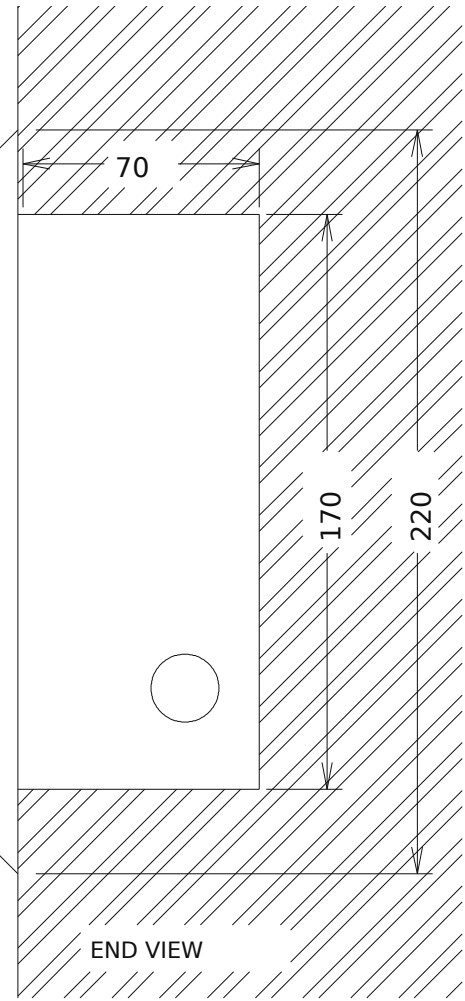
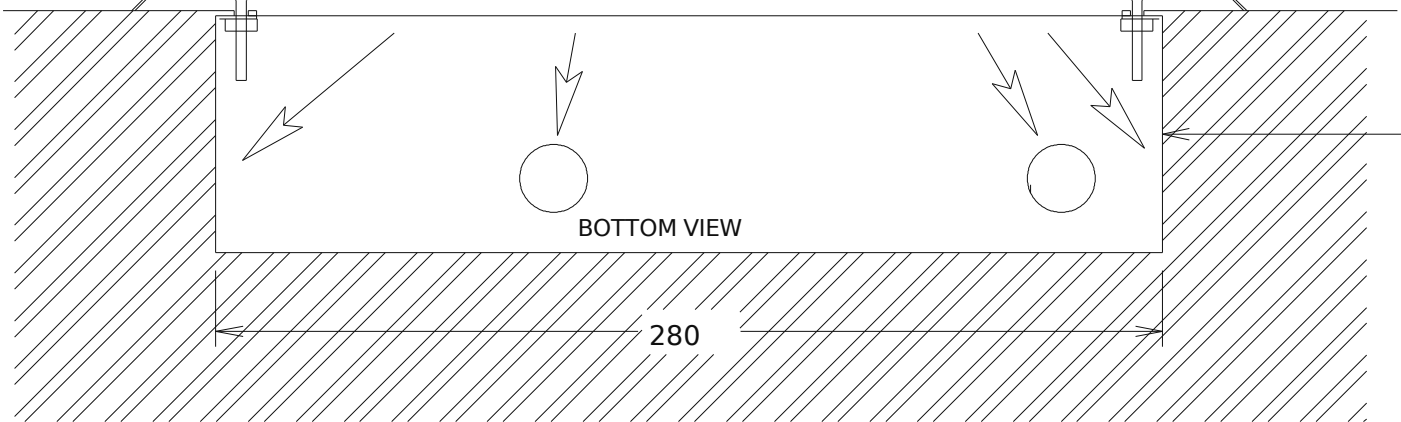
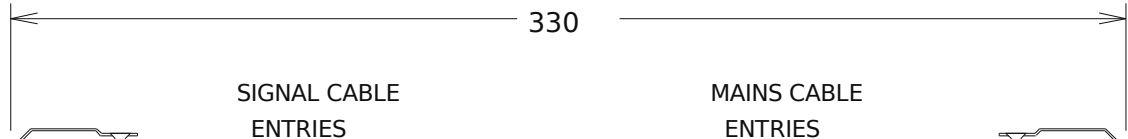
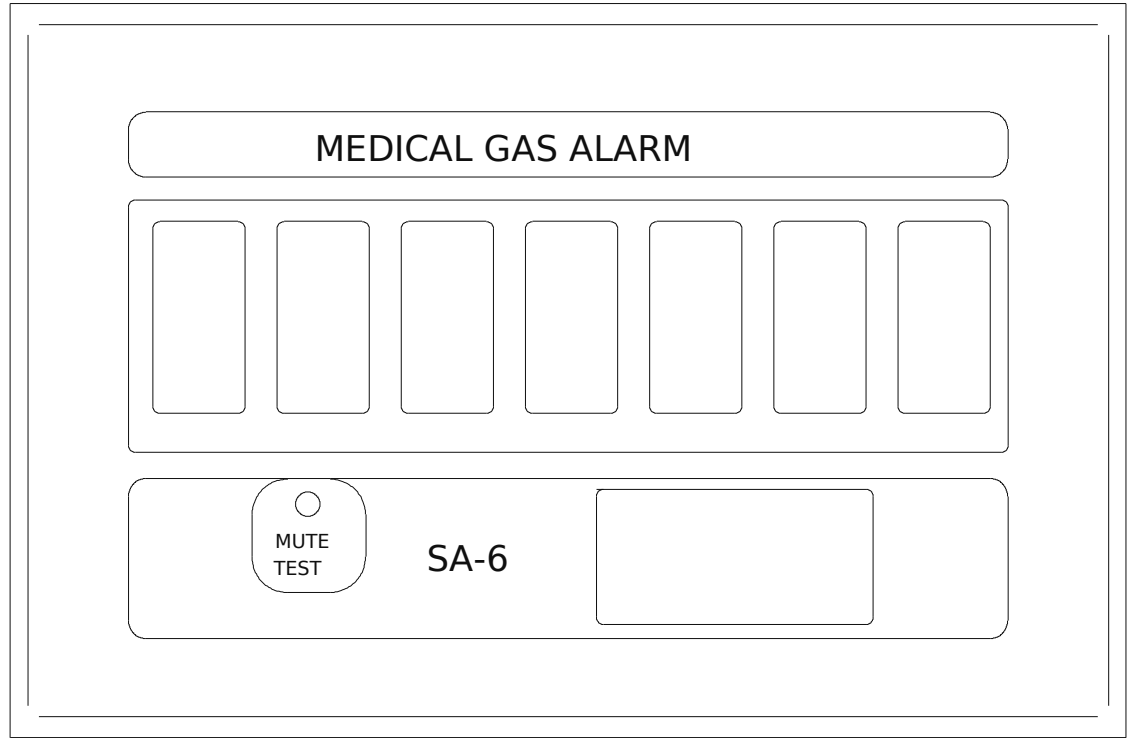

BACK BOX

FLUSH MOUNTING

DECLARATION OF CONFORMITY  
89/336 The EMC Directive  
73/23 The Low Voltage Directive  
ammended by 93/68

**Manufacturer**

Shire Controls Ltd  
Studio 3, Channoeks Farm  
Gilston .  
Harlow  
Essex  
CM202RL  
United Kingdom

**Product Type**

SA-6 Medical Gas Alarm , including computer interfaces, Termination boxes & remote audibles.

**Year of manufacture 2008**

**Standards used**

BSEN50081-1  
BSEN50082-1  
BSEN61000-3-2  
BSEN60950

**Authorised representative**

I.R.Couchman Technical Director

Signature



This work is licensed under the Creative Commons Attribution-NonCommercial 2.5 License. To view a copy of this license, visit <http://creativecommons.org/licenses/by-nc/2.5/> or send a letter to Creative Commons, 543 Howard Street, 5th Floor, San Francisco, California, 94105, USA.